

HOTPOI

Passive fluid management for cooking in microgravity

H. Larissa Zhou^{1*}, Adam Zachar², Dave Weitz¹
¹Harvard University; *zhou6@fas.harvard.edu; ²independent researcher

1 Motivation: Cooking in space

Food processing technologies are the missing link in a sustainable food supply chain for space habitation. Liquid-mediated cooking is of special interest for its application to a broad range of easily-prepared, shelf-stable ingredients.

2 Our Novel Design

Fluid management is a critical issue for cooking with liquids in microgravity. Drawing upon previous work for fluid management for propulsion and ECLSS, we employ a wedge/vane geometry and rely on capillary forces and surface tension to successfully achieve fluid management.

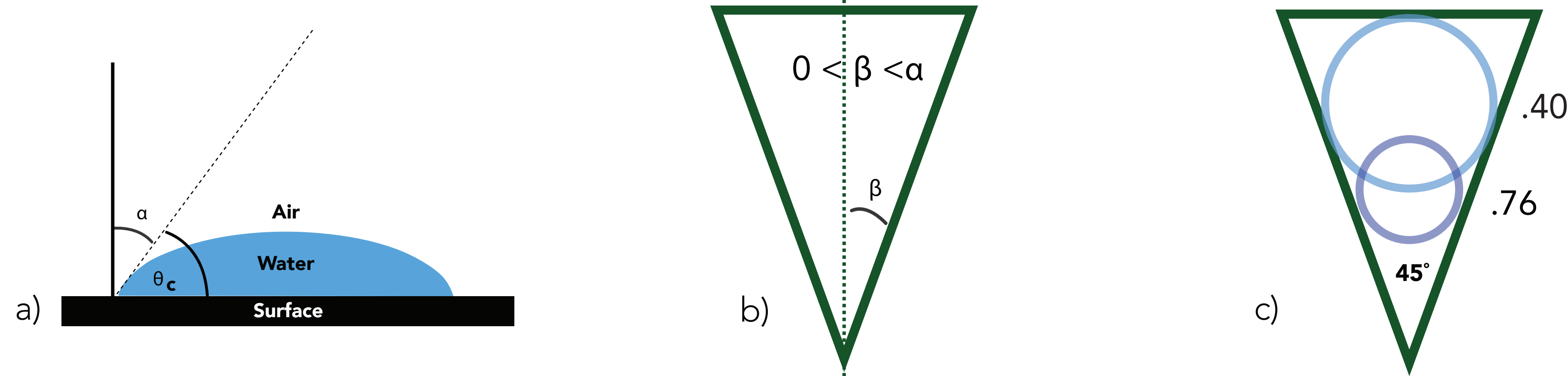

Fig 1 a,b) Given a contact angle, the cross-section of the 3D container is a wedge whose vertices satisfy the Concus-Finn wetting condition. 1c) Given bottom vertex angle of 45°, the allowable liquid fill fraction range is $.4 < x < .76$, with the expected ullage diameter as shown.

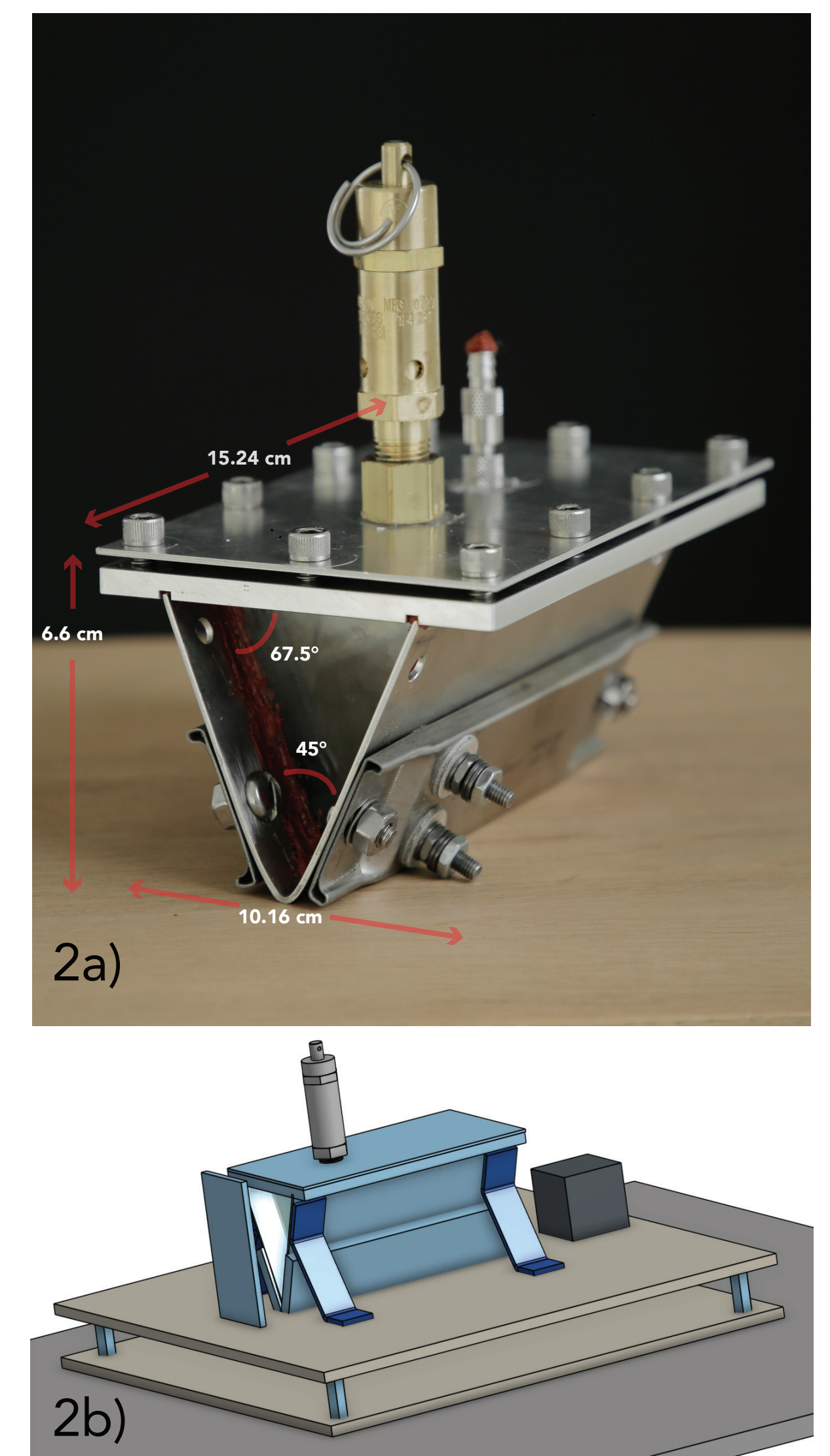
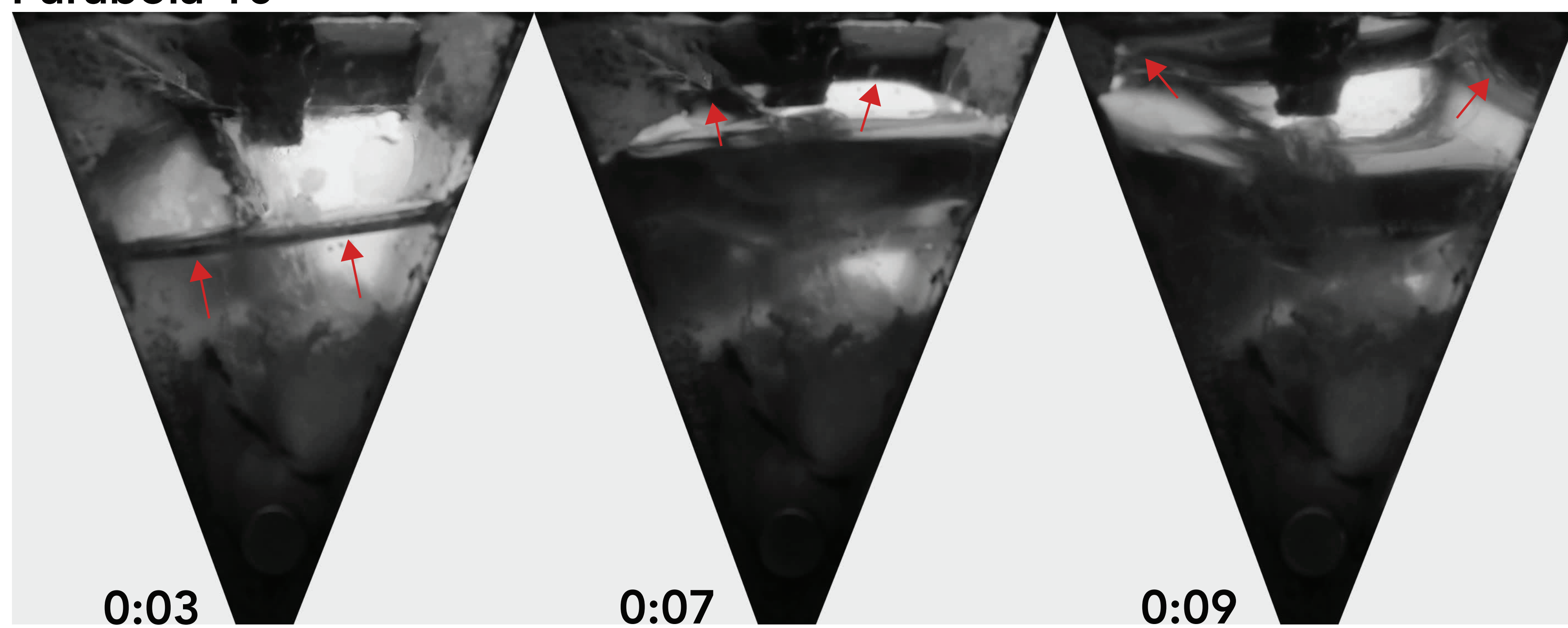

Fig 2a) Flight-ready device. 2b) Experimental platform showing positions of camera (in black) and LED backlight.

3 Preliminary results from parabolic flight

Fluid behavior

Parabola 10



3a) onset of microgravity

Fig 3a) During the onset of microgravity, water wicks up the sides and end caps of the wedge and fills the top vertices. 3b) At equilibrium, the ullage takes on a roughly cylindrical shape, neglecting the effect of the higher wettability of the borosilicate end caps, where an approximation of the expected ullage diameter is outlined in red.



3b) equilibrium in microgravity

Thermal Control

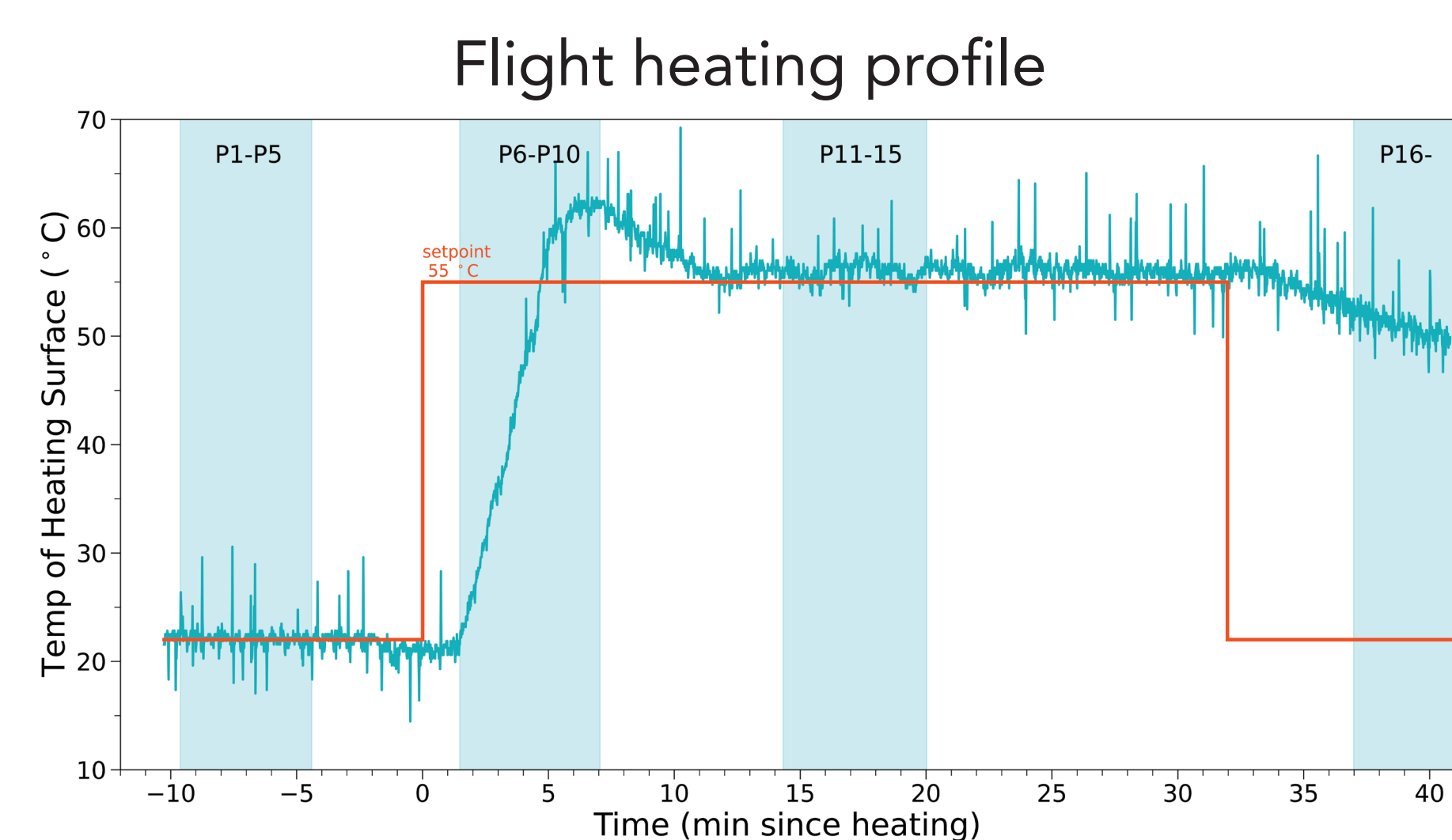

Fig 4. The thermal control loop uses a bang-bang controller with setpoint 55 °C.

Food Processing

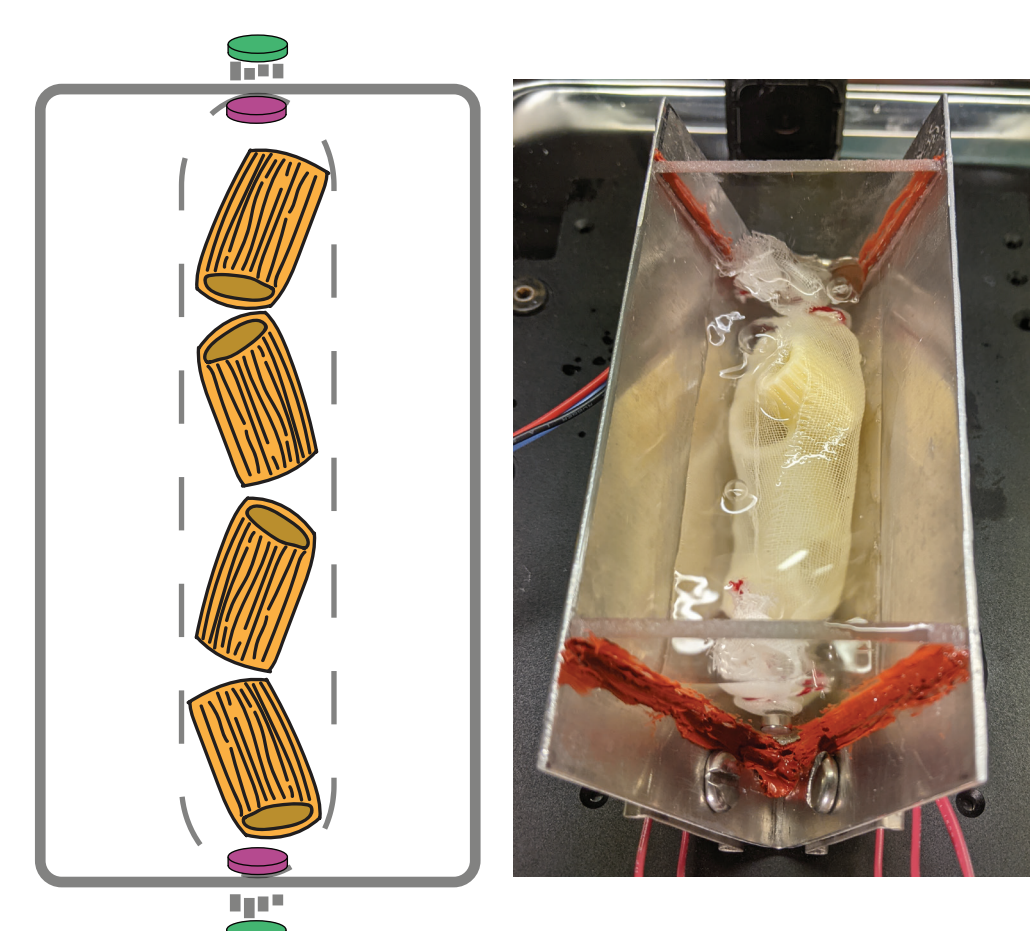
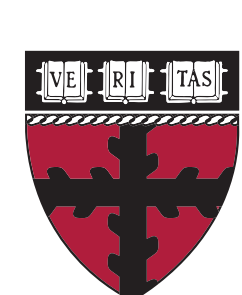

Fig 5. The food is contained in the wedge vertex via magnets.

4 Future Work

Future work involves designs that are gravity independent, which have the dual benefit of being operable in multiple gravity environments and testable on terrestrial platforms. Development paths include actively pressurized fluid systems and alternative heating methods such as in a gas or solid medium.



Harvard John A. Paulson School of Engineering and Applied Sciences

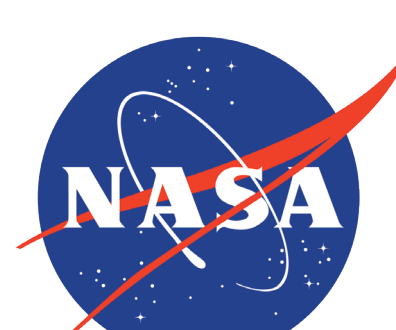

space exploration

Supported by NASA Grant #80NSSC19K1146 MIT Media Lab Space Exploration Initiative



SCAN ME